



POWER QUALITY SOLUTION



Complete Solution in Power Quality Correction



1. INTRODUCTION	
1.1 General	4
1.2 Power Factor	4
1.3 Reactive Power Demand	4
2. ECONOMIC EFFECT OF COMPENSATION	
2.1 Procurement Cost of Compensation	4
2.1.1 Generation of Reactive Power by Means of Rotating Machines	4
2.1.2 Procurement and Maintenance Cost of Capacitors	4
2.2 Transmission of Reactive Power and Design of the Network	5
2.3 Reactive Power and Transmission Losses	5
2.3.1 Active Power Losses	5
2.3.2 Reactive Power Losses	5
2.4 Reactive Power Transmission and Voltage Drop	6
2.4.1 Parallel Compensation	6
2.4.2 Series Compensation	6
3. METHODS OF COMPENSATION	
3.1 Individual Compensation	6
3.2 Central Compensation at Low Voltage	7
3.3 High Voltage Compensation	8
3.4 Technical Consequences of Compensation	9
3.4.1 Voltage Rise	9
3.4.2 Influence of Harmonics	9
3.4.3 Ambient Conditions	10
4. COMPENSATION EQUIPMENT	
4.1 Low Voltage Capacitors	11
4.1.1 Low Voltage Capacitor Units	11
4.1.2 Fixed Low Voltage Capacitor Banks	11
4.1.3 Automatically Controlled Low Voltage Capacitor Banks	11
4.2 High Voltage Capacitors	12
4.2.1 High Voltage Capacitor Units	12
4.2.2 High Voltage Capacitor Banks	12
4.3 Protection of Capacitor Banks	12
4.3.1 Internal and External Fuses	12
4.3.2 Unbalance Protection	13
4.3.3 Overcurrent and overvoltage protection	13
4.4 Harmonic Filters	13
4.5 Fast Static Compensators	14
4.6 Thyristor Controlled Capacitors	14
5. SUMMARY	14

1. INTRODUCTION

1.1 General

In addition to active power most electrical devices also demand reactive power.

If this reactive power is not provided by capacitors in the immediate vicinity, it must be transmitted via the distribution system. In this case the influence of the reactive power on the total current must be taken into account when designing the system, and this can lead to a need for larger transformers and cables than would otherwise be necessary.

Moreover, transmission of reactive power causes additional energy losses. By means of reactive power compensation the amount of reactive power has only little significance in dimensioning the system and on transmission losses.

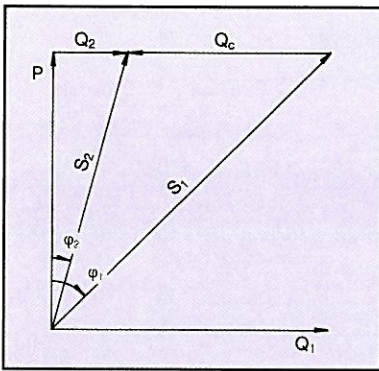

Fig.1 The apparent power of a network can be reduced by means of power factor correction (PFC).

- S_1 = apparent power before PFC
- S_2 = apparent power after PFC
- P = active power
- Q_1 = reactive power before PFC
- Q_2 = reactive power after PFC
- $Q_c = Q_1 - Q_2$ = compensation power of the capacitor
- φ_1 = phase angle before PFC
- φ_2 = phase angle after PFC

1.2 Power Factor

The total operating power, termed apparent power, can be expressed in terms of active and reactive power:

$$S = \sqrt{P^2 + Q^2} \quad (1)$$

Power factor $\cos\varphi$ represents the following relationship between active and apparent power:

$$\cos\varphi = \frac{P}{S} = \frac{\text{active power}}{\text{apparent power}} \quad (2)$$

Correspondingly

$$\tan\varphi = \frac{Q}{P} = \frac{\text{reactive power}}{\text{active power}} \quad (3)$$

Power factor correction (PFC) means that capacitors (or synchronous machines) are used to reduce the amount of reactive power in electricity supplies to industrial and commercial consumers, thus improving the power factor to a higher value.

1.3 Reactive Power Demand

Induction motors need reactive power to maintain the magnetic field essential for their operation. The average reactive power demand of asynchronous motors is approx. 1 kvar per 1 kW of active power.

Thyristor drives draw reactive current from the network and also generate harmonics which, among other things, tend to overload capacitors. In addition to the equipment mentioned above, transformers, loaded cables, transmission lines and various electrical devices all need reactive power to some extent.

Table 1. Examples of power factors

Load type	Approximate power factor (half ...full load)
Induction motor	< 100 kW 0.6...0.8 250 kW 0.8...0.9
Thyristor drives	0.7
Incandescent lamp (glow)	1.0
Mercury arc lamp	0.5
Fluorescent lamp (hot cathode)	0.5...0.6
Neon tube lamp	0.4...0.5
Induction furnace	0.2...0.6
Arc furnace	0.6...0.8
Electric heater	1.0
AC arc or resistance welder	0.5...0.6

2. ECONOMIC EFFECT OF COMPENSATION

During recent years increasing attention has been paid to minimizing the energy costs and inefficiencies in electricity generation, transmission, distribution and consumption.

When designing a compensation scheme one should attempt to achieve the most economical solution, in which the savings achieved in equipment costs and transmission losses are significantly greater than the procurement cost of the reactive power.

When positioning capacitors note that unfavourable ambient conditions can shorten the life of the units, effectively incurring extra expense. The cost of installing capacitors, the effect of power factor correction on the voltage level and the requirements of the electricity supply authority in regard to over-compensation, should also all be taken into account.

2.1 Procurement Cost of Compensation

2.1.1 Generation of Reactive Power by Means of Rotating Machines

Traditionally, reactive power has usually been generated by rotating machines and transmitted through the system to consumers in the same way as active power.

Large motors used in industry are often synchronous machines which themselves generate the reactive power they need.

It is often possible to arrange for these machines to be overmagnitized and thus generate excess reactive power for compensation of other loads. The procurement cost of the generators and synchronous machines depends on the desired extra amount of reactive power.

Generation of reactive power by synchronous machines incurs additional losses of 10...30 W/kvar, depending on the size and construction of the machine and the amount of reactive power generated. However, by raising the power factor, the additional losses can be reduced.

Reactive power produced by rotating machines must be transmitted through the distribution system. This leads to extra capital costs and additional transmission losses, which are especially significant at high voltage transmission.

It is now generally accepted that it is not advantageous to install such generators and synchronous motors specifically for the production of large amounts of reactive power and also that it is often uneconomical to produce reactive power

from synchronous machines that are already in the system.

This is a consequence of the rapid rise in energy prices in the 1970's and from development in system capital costs when compared with the purchase and maintenance cost of capacitors.

2.1.2 Procurement and Maintenance Cost of Capacitors

The procurement cost of capacitors can, for economic comparisons, be expressed in annual costs as follows:

$$K = a \cdot H \quad (4)$$

K = annual cost

a = cost factor of interest and depreciation

H = procurement cost of capacitors including installation

An interest rate of 7...10 % is generally used for calculations of profitability. The depreciation period for power capacitors is 15...20 years.

Annual operating costs comprise losses, maintenance and repair costs. Power losses have now been drastically reduced since film has replaced paper as the dielectric material for capacitors.

Annual expenses for maintenance and repair are usually 1...2 % of the purchase

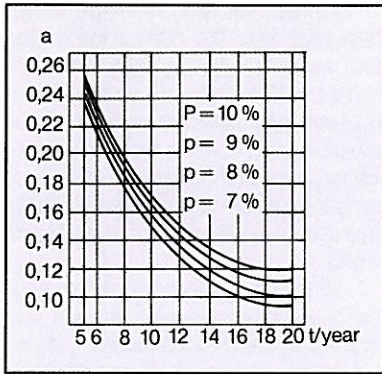

Fig. 2 Cost factor (a) derived from interest and depreciation.

price of the capacitor. Capacitor units have no moving or wearing parts. Contactors, regulating relays in automatic capacitor banks and breakers in HV banks are the only components that require maintenance.

An investment in capacitors will normally be reimbursed in 0.5...2 years through lower losses and reactive power/energy charges. The annual savings for the whole depreciation period are 30...100 % of the purchase price.

2.2 Transmission of Reactive Power and Design of the Network

The total current in the network is, as a rule, the basic criteria for designing the system. At low voltage in particular, the thermal current of the network is the critical factor, whereas at high voltage other considerations, such as short circuit power, are also vital.

When parallel compensation is included in the system, less reactive power is transmitted. Hence the corresponding current component I_q decreases, and consequently reduces the total current I which is expressed as follows:

$$I = \sqrt{I_p^2 + I_q^2} \quad (5)$$

I = current having effect on the design of the network
 I_p = current component caused by active power transmission

I_q = current component caused by reactive power transmission

Decreasing the current flowing in a new networks means that lower rated transformers, conductors and cables can be used. In an existing system more active power can be transmitted (I_p increases) when the reactive power transmission is cut down (I_q decreases) and the total load (I) remains constant.

By this means, replacement of the transformer or cables can possibly be postponed for some years or to the end of working life. The power that can be transmitted through the same network can be calculated from:

$$P_2 = P_1 \cdot \frac{\cos \varphi_2}{\cos \varphi_1} \quad (6)$$

P_1 = transmission capability of active power of the network at power factor $\cos \varphi_1$

P_2 = transmission capability of active power of the network at power factor $\cos \varphi_2$

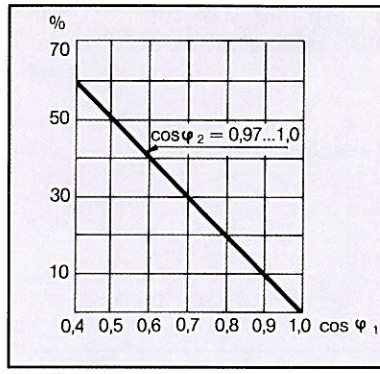

Fig. 3 Percentage decrease in design current of a network when the power factor ($\cos \varphi_2$) is improved to near unity.

2.3 Reactive Power and Transmission Losses

Transmission of reactive power causes active power loss in network resistance and loss of reactive power in reactances.

Due to the former, such system components as cables and transformers experience a temperature rise, and the power loss (kW) and corresponding energy (kWh) have to be paid for.

2.3.1 Active Power Losses

Active power losses in a 3-phase network can be calculated from the following formula:

$$P_n = 3 \times I^2 \times R = 3 \times I_p^2 \times R + 3 \times I_q^2 \times R \quad (7)$$

P_n = active power losses

R = resistance of the transmission network / phase

The above equation shows that power losses generated by the reactive current component (I_q) are independent of the active power transmission and can be examined separately:

$$P_{h_q} = 3 \times I_q^2 \times R \quad (8)$$

Note especially that power losses are incurred in proportion to the square of I_q , i.e. when the current rises 2-fold, losses will increase 4-fold. Correspondingly at a mean power factor of $\cos \varphi = 0.7$ for asynchronous motor load, half of the total transmission losses are due to the reactive power.

Resistance of cables can be roughly calculated from the formula:

$$R = k \times \frac{1}{A} \quad (9)$$

R = cable resistance

$k = 0.020 \Omega \times \text{mm}^2/\text{m}$ for Cu-cables

$= 0.033 \Omega \times \text{mm}^2/\text{m}$ for Al-cable

l = cable length

A = cross section area of the cable

Resistance of transformers may be calculated as follows:

$$R = r_k \times \frac{U^2}{S_n} \quad (10)$$

where

$$r_k = \frac{P_1}{S_n} \quad (11)$$

R = transformer resistance

S = rated power of transformer

U = supply voltage (by which the resistance is calculated)

r_k = relative short-circuit resistance

P_1 = load losses at rated current (from tables or rating plate)

When calculating losses, it is advisable to examine the various parts of the network separately. By this method the corresponding losses arising in cables, transformers etc. can be compared and the principal sources detected. This then becomes one criterion for the economical location of capacitors.

Annual costs of active power losses are:

$$C_a = (P_n \times a) + (P_n \times t_a \times b) \quad (12)$$

C_a = annual cost of active power losses

t_a = time that active power losses are being used

a = power charge

b = energy charge

If the power charge (or maximum demand charge) is not included in the tariff, the annual cost of loss energy is simply proportional to the length of time the equipment is used.

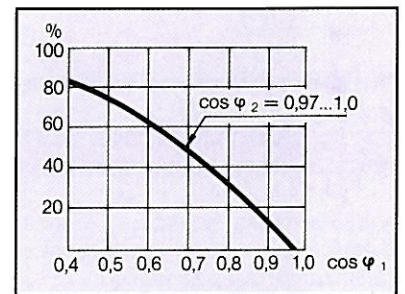

Fig. 4 Percentage decrease in total losses of a network with improvement in power factor.

2.3.2 Reactive Power Losses

Losses caused by reactive power transmission can be examined separately in the same way as active power losses. They are also independent of the active power transmission.

3-phase reactive power losses can be calculated from the following formula:

$$Q_{h_q} = 3 \times I_q^2 \times X \quad (13)$$

Q_{h_q} = reactive power losses due to reactive current component

X = network reactance

The reactance of an overhead line is calculated from its inductance:

$$X = 2 \times \pi \times f \times L \times l \quad (14)$$

X = line reactance

f = network frequency

L = specific inductance of the line

l = length of the line

The reactance of overhead lines is generally of the order of 0.4 ohm/km which is considerably more than that of cables. Reactive power losses generated in cables are normally insignificant.

The transformer reactance is calculated as follows:

$$X = x_k \times \frac{U^2}{S_n} \quad (15)$$

where

$$X_k = \sqrt{Z_k^2 - r_k^2} \quad (16)$$

- X = transformer reactance
- S_n = rated power of transformer
- U = supply voltage (at which reactance is calculated)
- Z_k = relative short-circuit impedance
- x_k = relative short-circuit reactance
- r_k = relative short-circuit resistance

The relative short-circuit impedance (Z_k) of power transformers is 2- or even 3-times that of distribution transformers.

2.4 Reactive Power Transmission and Voltage Drop

2.4.1 Parallel Compensation

Transmission of active power produces voltage drop across the resistances in a network and reactive power transmission causes voltage drop in the inductive reactances. The total voltage drop can be calculated approximately from the following formula:

$$dU = I_p \times R + I_q \times X \quad (17)$$

- dU = voltage drop (phase voltage)
- R = network resistance
- X = network reactance

This shows that the voltage drop in the system reactances can be decreased by reducing the reactive current component, typically by using parallel or, as it is also called, shunt compensation (Fig.5).

With transformers, the voltage drop caused by transmission of reactive power is relatively high. This drop can be calculated from the following formula:

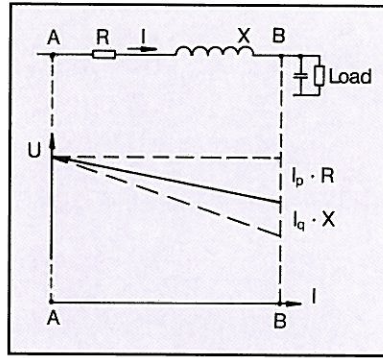

Fig. 5 Parallel compensation reduces the voltage drop.

$$U_d = \frac{I}{I_n} (r_k \times \cos \varphi + X_k \times \sin \varphi) \quad (18)$$

- U_d = relative voltage drop in the transformer
- $\cos \varphi$ = power factor of load
- I_n = rated current of transformer
- I = load current

2.4.2 Series Compensation

As previously stated, shunt compensation reduces the reactive component of the network current and, consequently, the voltage drop. With series compensation, the line reactance is decreased by connecting capacitors in series with the line. The expression (17) for line voltage drop is then modified as follows:

$$dU = I_p \times R + I_q \times (X_l - X_c) \quad (19)$$

- dU = voltage drop in the line
- X_l = line reactance
- X_c = capacitor reactance

When X_c equals X_l , the network reactance is zero ($X_l - X_c = 0$) and the voltage drop caused by reactive power transmission is therefore also zero. By inclusion of a suitable series capacitor, X_c may be made greater than X_l , in which case the network reactance becomes negative. Thus, series compensation can also reduce the voltage drop caused by active power transmission (Fig.6).

In addition, series capacitors provide the following advantages compared with uncompensated HV transmission systems: higher power transmission capability, better static and dynamic stability, fewer regulation requirements and reduced losses

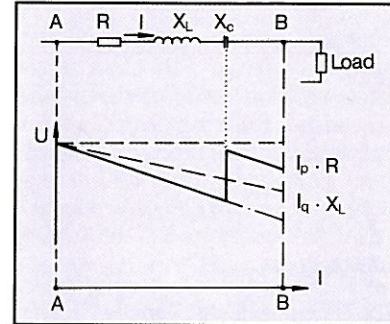

Fig. 6 Voltage may be raised to the desired level by means of a series capacitor

through optimizing load sharing in parallel lines. Series compensation is also a cost-saving alternative compared with building new, parallel lines.

3. METHODS OF COMPENSATION

When selecting the method of compensation required one should consider the location of the capacitors, the economic aspects referred to above such as tariffs, the parameters of the network, transmission losses and voltage drop, as well as the initial purchase cost and maintenance expenses of the equipment. In addition, there are factors such as system harmonics and the ambient conditions which may limit the effective utilization of capacitors.

Tables and nomograms are available to assist in calculating the capacitor rating required. In table 2 the cross-reading of given and desired values of $\cos \varphi$ or $\tan \varphi$ gives the factor K , by which the active power P shall be multiplied. This yields the capacitor rating to be chosen.

There is no single method of compensation to be recommended universally; various methods can be applicable in each case.

In the following three methods of parallel compensation will be discussed: individual, group and central compensation.

3.1 Individual Compensation

By connecting the capacitors to the terminals of the compensated equipment, one can best consider the influence of the ca-

pacitors on the network dimensioning and on power and voltage losses.

The reactive power demand of 3-phase asynchronous motors varies between 0.5 and 1 kvar per kilowatt of active power depending on the speed, size and load of the motors. Most of the reactive power needed can be produced by capacitors installed in parallel with the motor. The capacitor can be connected either to the terminals of the motor or of the starter (Fig.7).

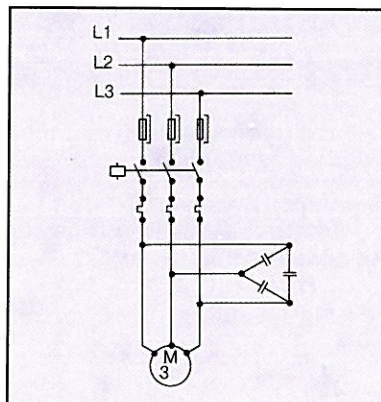

Fig. 7 Principle of individual motor compensation

The necessary capacitor rating may be calculated from the formula:

$$Q_c = \frac{P}{\eta} \times (\tan \varphi_1 - \tan \varphi_2) \quad (20)$$

- Q_c = capacitor output
- P = rated power of motor
- η = efficiency of motor
- φ_1 = phase angle before PFC
- φ_2 = phase angle after PFC

A voltage rise caused by self-excitation can occur particularly when the motor is quickly re-connected immediately after switching off. It is therefore advisable to limit the compensation power to:

$$Q_c = 0.9 \times I_0 \times U \times \sqrt{3} \quad (21)$$

- I_0 = no-load current of the motor
- U = supply voltage

Because of self-excitation, it is not recommended to use individual motor compensation if the machine driven by the motor can in turn rotate it at overspeed (cranes, carriers, etc.) or if the brake magnet voltage is derived from the poles of the motor.

When dimensioning the capacitor cable note that the fuses also protect the supply cable. Thus the capacitor cable should have the same cross-section as that of the main motor cable.

Also when setting any overcurrent relay, notice that the compensation reduces the current.

Table 2. Desired power factor in percent

	80	81	82	83	84	85	86	87	88	89	90	91	92	93	94	95	96	97	98	99	100
50	0.982	1.003	1.034	1.069	1.084	1.112	1.139	1.165	1.192	1.220	1.248	1.276	1.305	1.337	1.369	1.403	1.442	1.481	1.529	1.590	1.732
51	0.937	.962	.989	1.015	1.041	1.067	1.094	1.120	1.147	1.175	1.203	1.231	1.261	1.292	1.324	1.358	1.395	1.436	1.484	1.544	1.687
52	.893	.919	.945	.971	.997	1.023	1.050	1.076	1.103	1.131	1.159	1.187	1.217	1.248	1.280	1.314	1.351	1.392	1.440	1.500	1.643
53	.850	.876	.902	.928	.954	.980	1.007	1.033	1.060	1.088	1.116	1.144	1.174	1.205	1.237	1.271	1.308	1.349	1.397	1.457	1.600
54	.809	.835	.861	.837	.913	.939	.966	.982	1.019	1.047	1.075	1.103	1.133	1.164	1.196	1.230	1.267	1.308	1.356	1.416	1.559
55	.769	.795	.821	.847	.873	.899	.926	.962	.979	1.007	1.035	1.063	1.090	1.124	1.156	1.190	1.228	1.268	1.316	1.377	1.519
56	.730	.756	.782	.808	.834	.860	.887	.913	.940	.968	.996	1.024	1.051	1.085	1.117	1.151	1.189	1.229	1.277	1.338	1.480
57	.692	.718	.744	.770	.796	.822	.849	.875	.902	.930	.958	.986	1.013	1.047	1.079	1.113	1.151	1.191	1.239	1.300	1.442
58	.655	.681	.707	.733	.759	.785	.812	.838	.865	.893	.921	.949	.976	1.010	1.042	1.076	1.114	1.154	1.202	1.263	1.405
59	.618	.644	.670	.696	.722	.748	.775	.801	.828	.856	.884	.912	.939	.973	1.005	1.039	1.077	1.117	1.165	1.226	1.368
60	.584	.610	.636	.662	.688	.714	.741	.767	.794	.822	.850	.878	.905	.939	.971	1.005	1.043	1.083	1.131	1.192	1.334
61	.549	.575	.601	.627	.653	.679	.706	.732	.759	.787	.815	.843	.870	.904	.936	.970	1.008	1.048	1.096	1.157	1.299
62	.515	.541	.567	.593	.619	.645	.672	.698	.725	.753	.781	.809	.836	.870	.902	.936	.974	1.014	1.062	1.123	1.265
63	.483	.509	.535	.561	.587	.613	.640	.666	.693	.721	.749	.777	.804	.838	.870	.904	.942	.982	1.030	1.091	1.233
64	.450	.476	.502	.528	.554	.580	.607	.633	.660	.688	.716	.744	.771	.805	.837	.871	.909	.949	.997	1.058	1.200
65	.419	.445	.471	.497	.523	.549	.576	.602	.629	.657	.685	.713	.740	.774	.806	.840	.878	.918	.966	1.027	1.169
66	.396	.414	.440	.466	.492	.518	.545	.571	.598	.626	.654	.682	.709	.743	.775	.809	.847	.887	.935	.996	1.138
67	.358	.384	.410	.436	.462	.488	.515	.541	.568	.596	.624	.652	.679	.713	.745	.779	.817	.857	.905	.966	1.108
68	.329	.355	.381	.407	.433	.459	.486	.512	.539	.567	.595	.623	.650	.684	.716	.750	.788	.828	.876	.937	1.079
69	.299	.325	.351	.377	.403	.429	.456	.482	.509	.537	.565	.593	.620	.654	.686	.720	.758	.798	.840	.901	1.043
70	.270	.296	.322	.348	.374	.400	.427	.453	.480	.508	.536	.564	.591	.625	.657	.691	.729	.769	.811	.872	1.014
71	.242	.268	.294	.320	.346	.372	.399	.425	.462	.488	.508	.536	.563	.597	.629	.663	.701	.741	.783	.850	.992
72	.213	.239	.263	.291	.317	.343	.370	.396	.423	.451	.479	.507	.534	.568	.600	.634	.672	.712	.754	.821	.963
73	.188	.212	.238	.264	.290	.316	.343	.369	.396	.424	.452	.480	.507	.541	.573	.607	.645	.685	.727	.794	.936
74	.159	.185	.211	.237	.263	.289	.316	.342	.369	.397	.425	.453	.480	.514	.546	.580	.618	.658	.700	.767	.909
75	.132	.158	.184	.210	.236	.262	.289	.315	.342	.370	.398	.426	.453	.487	.519	.553	.591	.631	.673	.740	.882
76	.105	.131	.157	.183	.209	.235	.262	.288	.315	.343	.371	.399	.426	.460	.492	.526	.564	.604	.652	.713	.855
77	.079	.105	.131	.157	.183	.209	.236	.262	.289	.317	.345	.373	.400	.434	.466	.500	.538	.578	.620	.687	.829
78	.053	.079	.105	.131	.157	.183	.210	.236	.263	.291	.319	.347	.374	.408	.440	.474	.512	.552	.594	.661	.803
79	.026	.052	.078	.104	.130	.156	.183	.209	.236	.264	.292	.320	.347	.381	.413	.447	.485	.525	.567	.634	.776
80	.000	.026	.052	.078	.104	.130	.157	.183	.210	.238	.266	.294	.321	.355	.387	.421	.459	.499	.541	.608	.750
81000	.026	.052	.078	.104	.131	.157	.184	.212	.240	.268	.295	.329	.361	.395	.433	.473	.515	.582	.724
82000	.026	.052	.078	.105	.131	.158	.186	.214	.242	.269	.303	.335	.369	.407	.447	.489	.556	.698
83000	.026	.052	.079	.105	.132	.160	.188	.216	.243	.277	.309	.343	.381	.421	.463	.530	.672
84000	.026	.053	.079	.106	.134	.162	.190	.217	.251	.283	.317	.355	.395	.437	.504	.646
85000	.027	.053	.080	.108	.136	.164	.191	.225	.257	.291	.329	.369	.417	.478	.620
86026	.053	.081	.109	.137	.167	.198	.230	.265	.303	.343	.390	.451	.593
87027	.055	.082	.111	.141	.172	.204	.238	.275	.317	.384	.425	.567
88028	.056	.084	.114	.145	.177	.211	.248	.290	.337	.398	.540
89028	.056	.086	.117	.149	.183	.220	.252	.309	.370	.512
90028	.058	.089	.121	.155	.192	.234	.281	.342	.484
91030	.061	.093	.127	.164	.206	.253	.314	.456
92031	.063	.087	.134	.176	.223	.284	.426
93032	.066	.103	.145	.192	.253	.395
94034	.071	.113	.160	.221	.363
95037	.079	.126	.187	.328

Original power factor in percent

Figures from chart x Kw load = kvar of capacitors required for power-factor correction

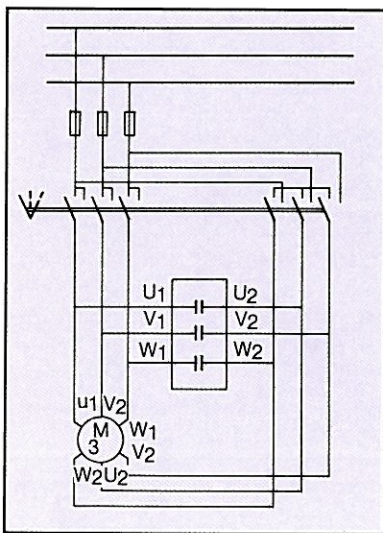

Fig.8 Connection of a capacitor for a motor with a mechanical Y/D starter

If the motor is equipped with an automatic star-delta starter where the motor is switched off directly from the delta configuration, a normally connected capacitor may be used for power factor correction.

However, if a mechanical star-delta starter is used as in Fig.8, capacitors that are specifically designed for this purpose must be fitted. Single-phase capacitors are connected in parallel with each winding of the motor.

3.2 Central Compensation at Low Voltage

Though individual or group compensation may be used, additional capacitors are often installed at the main supply point to achieve a sufficient degree of correction ($\cos\phi \geq 0.97$). A proportion of the required compensation may be supplied as fixed units and the remainder in automatically controlled capacitor banks as shown in Fig.9.

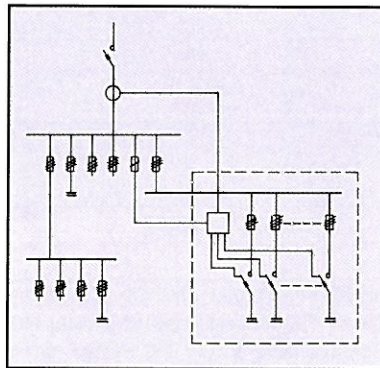

Fig.9 Connection scheme comprising fixed capacitors and automatically controlled capacitor bank.

Capacitors that are permanently connected to the system are continuously producing reactive power, even at periods of low load. Thus, any excess reactive power is transferred into the main supply network.

Reactive power consumption of a distribution transformer at no-load is 1...2 % and at full load 4...7 % of its rated power (see table 3).

To avoid the disadvantages of over-compensation, the total power of the fixed capacitors should be limited to 10...15 % of the transformer rating. A fuse switch or circuit breaker is generally fitted, so that the capacitor may be switched off if required.

Table 3. Approximate reactive power consumption of various 60 Hz distribution transformers (primary voltage 10...20 kV)

Power rating kVA	Reactive power consumption Kvar	
	no-load	full load
16	0.3	1.0
30	0.5	1.7
50	0.8	2.8
100	1.5	5.5
200	3	13
315	4	20
500	6	31
800	9	40
1000	10	70
1250	11	96
1600	13	109
2000	14	134

In an automatic capacitor bank, a reactive power regulator controls the switching of

Table 4a. Suggested Maximum Capacitor Ratings for Pre-U-Frame NEMA Design B230 V, 460 V, 575 V Squirrel-Cage Motors

Nominal Motor Speed													
Induction Motor Rating (hp)	3600 r/min.		1800 r/min.		1200 r/min.		900 r/min.		720 r/min.		600 r/min.		Line Current Reduction (%)
	Capacitor Rating (kvar)	Line Current Reduction (%)	Capacitor Rating (kvar)	Line Current Reduction (%)	Capacitor Rating (kvar)	Line Current Reduction (%)	Capacitor Rating (kvar)	Line Current Reduction (%)	Capacitor Rating (kvar)	Line Current Reduction (%)	Capacitor Rating (kvar)	Line Current Reduction (%)	
3	1.5	14	1.5	15	1.5	20	2	27	2.5	35	3.5	41	
5	2	12	2	13	2	17	3	25	4	32	4.5	37	
7 1/3	2.5	11	2.5	12	3	15	4	22	5.5	30	6	34	
10	3	10	3	11	3.5	14	5	21	6.5	27	7.5	31	
15	4	9	4	10	5	13	6.5	18	8	23	9.5	27	
20	5	9	5	10	6.5	12	7.5	16	9	21	12	25	
25	6	9	6	10	7.5	11	9	15	11	20	14	23	
30	7	8	7	9	9	11	10	14	12	18	16	22	
40	9	8	9	9	11	10	12	13	15	16	20	20	
50	12	8	11	9	13	10	15	12	19	15	24	19	
60	14	8	14	8	15	10	18	11	22	15	27	19	
75	17	8	16	8	18	10	21	10	26	14	32.5	18	
100	22	8	21	8	25	9	27	10	32.5	13	40	17	
125	27	8	26	8	30	9	32.5	10	40	13	47.5	16	
150	32.5	8	30	8	35	9	37.5	10	47.5	12	52.5	15	
200	40	8	37.5	8	42.5	9	47.5	10	60	12	65	14	
250	50	8	45	7	52.5	8	57.5	9	70	11	77.5	13	
300	57.5	8	52.5	7	60	8	65	9	80	11	87.5	12	
350	65	8	50	7	67.5	8	75	9	87.5	10	95	11	
400	70	8	65	6	75	8	85	9	95	10	105	11	
450	75	8	67.5	6	80	8	92.5	9	100	9	110	11	
500	77.5	8	72.5	6	82.5	8	97.5	9	107.5	9	115	10	

NOTE: Applies to three-phase, 60 Mz motors when switched with capacitors as a single unit from ANSI/IEEE C37.012-1979 (21).

Table 4b. Suggested Maximum Capacitor Ratings for U-Frame NEMA Design B230 V, 460 V, 575 V Squirrel-Cage Motors

Nominal Motor Speed													
Induction Motor Rating (hp)	3600 r/min.		1800 r/min.		1200 r/min.		900 r/min.		720 r/min.		600 r/min.		Line Current Reduction (%)
	Capacitor Rating (kvar)	Line Current Reduction (%)	Capacitor Rating (kvar)	Line Current Reduction (%)	Capacitor Rating (kvar)	Line Current Reduction (%)	Capacitor Rating (kvar)	Line Current Reduction (%)	Capacitor Rating (kvar)	Line Current Reduction (%)	Capacitor Rating (kvar)	Line Current Reduction (%)	
2	1	17	1	20	1	23	1	24	-	-	-	-	
3	1	11	1	16	1	19	2	24	-	-	-	-	
5	1	9	2	15	2	19	2	20	-	-	-	-	
7 1/3	1	6	2	13	4	19	4	20	-	-	-	-	
10	2	5	2	11	4	16	5	15	5	17	5	21	
15	4	6	4	11	4	13	5	15	5	17	5	21	
20	4	6	5	11	5	13	5	15	10	17	10	21	
25	5	5	5	8	5	9	5	15	10	17	10	18	
30	5	6	5	8	5	9	10	15	10	15	10	18	
40	5	6	10	8	10	9	10	15	10	15	15	17	
50	5	6	10	8	10	9	15	12	15	12	20	17	
60	10	6	10	8	10	9	15	12	20	12	25	17	
75	15	6	15	8	15	9	20	11	25	12	30	17	
100	15	6	20	8	25	9	25	11	40	12	45	17	
125	20	6	25	7	30	9	30	11	45	12	45	15	
150	25	6	30	7	30	9	40	11	45	12	50	15	
200	35	6	40	7	60	9	55	11	55	11	60	13	
250	40	5	40	6	60	9	80	11	60	11	100	13	
300	45	5	45	6	80	8	80	10	80	10	120	13	
350	60	5	70	6	80	8	80	9	-	-	-	-	
400	60	5	80	6	80	6	160	-	-	-	-	-	
450	70	5	100	6	-	-	-	-	-	-	-	-	
500	70	5	-	-	-	-	-	-	-	-	-	-	

NOTE: Applies to three-phase, 60 Mz motors when switched with capacitors as a single unit

the capacitor steps according to the varying reactive power requirements. Inductive and capacitive operating limits for the regulator are set and the amount of reactive power in the network is maintained within these limits. Problems of overcompensation therefore do not arise.

The effects of central compensation on the dimensioning of a network and on the losses are mainly related to the distri-

bution transformer and the connecting cable. The electricity board system can therefore benefit from low voltage power factor correction, and this is usually taken into account when connection charges and annual tariffs are determined.

3.3 High Voltage Compensation

Compensation may also be carried out on the high voltage side, in which case there

are no cost savings related to the dimensioning and losses of the distribution transformers. Because of the high reactance of transformers, considerable voltage drops and reactive power losses are also incurred by reactive power transmission. Thus, compared with LV compensation, more capacitors would be needed on the HV side of a transformer.

It is possible to compensate HV mo-

Table 4c. Suggested Maximum Capacitor Ratings for T-Frame NEMA Design B230 V, 460 V, 575 V Squirrel-Cage Motors

Nominal Motor Speed																		
Induction Motor Rating (hp)	3600 r/min.			1800 r/min.			1200 r/min.			900 r/min.			720 r/min.			600 r/min.		
	Capacitor Rating (kvar)	Line Current Reduction (%)	Line Current Reduction (%)	Capacitor Rating (kvar)	Line Current Reduction (%)	Line Current Reduction (%)	Capacitor Rating (kvar)	Line Current Reduction (%)	Line Current Reduction (%)	Capacitor Rating (kvar)	Line Current Reduction (%)	Line Current Reduction (%)	Capacitor Rating (kvar)	Line Current Reduction (%)	Line Current Reduction (%)	Capacitor Rating (kvar)	Line Current Reduction (%)	Line Current Reduction (%)
3	1.5	14	23	1.5	23	2.5	28	3	38	3	40	4	40	4	40	4	40	40
5	2	14	22	2.5	22	3	26	4	31	4	40	5	40	5	40	5	40	40
7½	2.5	14	20	3	20	4	21	5	28	5	38	6	45	6	45	6	45	45
10	4	14	18	4	18	5	21	6	27	7.5	36	8	38	8	38	8	38	38
15	5	12	18	5	18	6	20	7.5	24	8	32	10	34	10	34	10	34	34
20	6	12	17	6	17	7.5	18	9	23	10	29	12	30	12	30	12	30	30
25	7.5	12	17	7.5	17	8	19	10	23	12	25	18	30	18	30	18	30	30
30	8	11	16	8	16	10	19	14	22	15	24	22.5	30	22.5	30	22.5	30	30
40	12	12	15	13	15	16	19	18	21	22.5	24	25	30	24	25	25	30	30
50	15	12	15	18	15	20	19	22.5	21	24	24	30	30	24	30	30	30	30
60	18	12	14	21	14	22.5	17	26	20	30	22	35	28	30	22	35	28	28
75	20	12	14	23	14	25	15	28	17	33	14	40	19	33	14	40	19	19
100	22.5	11	14	30	14	30	12	36	16	40	15	45	17	40	15	45	17	17
125	25	10	12	35	12	35	12	42	14	45	15	50	17	45	15	50	17	17
150	30	10	12	42	12	40	12	52.5	14	52.5	14	60	17	52.5	14	60	17	17
200	35	10	11	50	11	50	10	66	13	68	13	90	17	68	13	90	17	17
250	40	11	10	60	10	62.5	10	82	13	87.5	13	100	17	87.5	13	100	17	17
300	45	11	10	68	10	75	12	100	14	100	13	120	17	100	13	120	17	17
350	50	12	8	75	8	90	12	120	13	120	13	135	15	120	13	135	15	15
400	75	10	8	80	8	100	12	130	13	140	13	150	15	140	13	150	15	15
450	90	8	8	90	8	120	10	140	12	160	14	160	15	160	14	160	15	15
500	100	8	9	120	9	150	12	150	12	180	13	180	15	180	13	180	15	15

NOTE: Applies to three-phase, 60 Mz motors when switched with capacitors as a single unit

tors individually in the same way as with low voltage. For this purpose enclosed capacitor banks are manufactured, which can then, if required, be installed adjacent to the motor.

Generally HV capacitor banks are used to compensate for the reactive power consumed by long transmission lines and power transformers. Sometimes it is economical to compensate for part of the reactive power of a large industrial plant by means of HV capacitor banks.

However, because of the relatively high cost of the connecting equipment (viz: circuit-breaker, protection, cables, busbar), the total cost per kvar may seem unreasonably high if compared with straightforward HV capacitor banks.

3.4 Technical Consequences of Compensation

3.4.1 Voltage Rise

Fixed capacitors can cause the voltage to rise in an unloaded network. The rise in a transformer on no-load may be calculated from the following formula:

$$d_u (\%) = \frac{Q_c}{S_n} \cdot x_k (\%) \quad (23)$$

d_u = percentage voltage rise
 Q_c = rated power of capacitor bank
 S_n = rated power of transformer
 x_k = percentage short circuit reactance of transformer

In practice voltage rises of 1..2 % are experienced during no-load operation.

If, for example, the proportion of fixed capacitors is 20 % of the rated power of the transformer and $x_k = 6 \%$, the voltage of the transformer rises 1.2 % during no-load operation.

3.4.2 Influence of Harmonics

Non-linear loads, such as thyristor drives, converters and arc furnaces produce excessive harmonic currents causing both current and voltage distortion. Capacitors offer a low impedance to any higher frequencies flowing through them, but they also may amplify the effect of harmonic currents flowing into other parts of the network.

The effect of harmonics on the phase voltage of a capacitor bank can be calculated from the following formula:

$$U_p = \sum \frac{I_{cn}}{n \cdot 2 \cdot \pi \cdot f_1 \cdot C} \quad (24)$$

U_p = phase voltage of capacitor bank
 n = order of harmonic (the harmonic frequency $fn = n \cdot$ basic frequency)
 I_{cn} = 'n'th harmonic current flowing into capacitor bank
 f_1 = basic frequency (e.g. 50 Hz)
 C = capacitance of bank per phase

In other words, the voltage component of each harmonic is summed arithmetically at the basic frequency voltage. When designing a compensation scheme, the harmonics flowing into the bank must be calculated on the basis of the harmonic current imposed by the load. The harmonics in an existing capacitor bank can be measured by a harmonic analyser.

The harmonics flowing into the capacitor bank can in some circumstances be very high. The worst situation arises when the capacitors and the network inductance form a parallel or series resonant circuit under the following conditions:

$$n = \sqrt{\frac{X_c}{X_1}} = \sqrt{\frac{S_k}{Q_c}} \quad (25)$$

X_c = capacitive reactance of bank at basic frequency
 X_1 = inductive short circuit reactance of network at basic frequency
 Q_c = reactive power of capacitor bank
 S_k = short circuit power of network

Connecting a harmonic source and capacitors to the same busbar could create a parallel resonant circuit. Similarly a capacitor bank connected to the LV side of a transformer can form a series resonant circuit with the transformer for harmonics originating on the HV side. When carrying out reactive power compensation, one should avoid the danger of resonance at any of the common orders of harmonics (viz: 3rd, 5th, 7th, 11th and 13th).

The capacitor rating which could cause resonance if connected to the network, can be calculated for each harmonic as follows:

$$Q_c = \frac{S_k}{n^2} \quad (26)$$

For example, if the short-circuit power of the busbar is 15 MVA the equation (26) yields

$$\text{for } n = 3 : Q_c = \frac{15}{3^2} \text{ Mvar} = 1.7 \text{ Mvar}$$

$$\text{for } n = 5 : Q_c = \frac{15}{5^2} \text{ Mvar} = 0.6 \text{ Mvar}$$

$$\text{for } n = 7 : Q_c = \frac{15}{7^2} \text{ Mvar} = 0.3 \text{ Mvar}$$

For higher harmonics the possibility of resonance is generally slight but it must be taken into account if the harmonic content is very high.

The rated current of the thyristor drive system shown in Fig.10 is calculated by using a power factor of 0.7, a diversity

Example

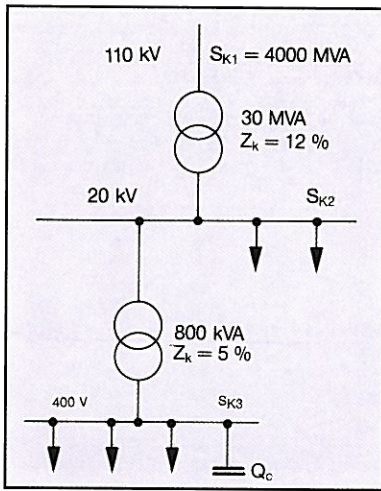

Fig.10 Schematic diagram of the example

factor of 0.8 and motor efficiency of 95 % as follows:

$$I = \frac{P}{\sqrt{3} \cdot U \cdot e \cdot \cos \varphi}$$

$$= \frac{0.8 \cdot 3 \cdot 100000}{\sqrt{3} \cdot 380 \cdot 0.95 \cdot 0.7} = 550 \text{ A}$$

The harmonics caused by thyristor drives are usually generated by 6-pulse rectifiers in the following percentages of rated current:

- 5th harmonic (30 %):
 $I_5 = 0.3 \cdot 550 \text{ A} = 165 \text{ A}$
- 7th harmonic (12 %):
 $I_7 = 0.12 \cdot 550 \text{ A} = 66 \text{ A}$
- 11th harmonic (6 %):
 $I_{11} = 0.06 \cdot 550 \text{ A} = 33 \text{ A}$
- 13th harmonic (5 %):
 $I_{13} = 0.05 \cdot 550 \text{ A} = 28 \text{ A}$

The capacitance and reactance (at power frequency) of a 200 kvar capacitor bank are

$$C = \frac{Q_c}{2 \cdot \pi \cdot f \cdot U^2} = \frac{200000}{314 \cdot 400^2} = 3.98 \cdot 10^{-3} \text{ F}$$

$$X_c = \frac{1}{2 \cdot \pi \cdot f \cdot C} = \frac{U^2}{Q_c} = \frac{400^2}{200000} = 0.8 \Omega$$

If the network impedance is simplified, consisting of only inductive reactance, it can be expressed as

$$X_k = \frac{U^2}{S_k} = \frac{400^2}{15 \cdot 10^6} = 0.01067 \Omega$$

At 'n'th harmonic frequency the reactances of the capacitor bank and network are

$$X_{c,n} = \frac{X_c}{n} \tag{27}$$

$$X_{k,n} = n \cdot X_k \tag{28}$$

$X_{c,n}$ = capacitive reactance of the bank at 'n'th harmonic frequency

X_c = capacitive reactive of the bank at basic frequency

$X_{k,n}$ = inductive reactance of the network at 'n'th harmonic

X_k = inductive reactance of the network at basic frequency

The harmonic currents flowing into the bank ($I_{c,n}$) and into the network ($I_{k,n}$) are calculated simply by using the current division rule when the currents of the harmonic source (I_n) are known:

$$I_{c,n} = \left(\frac{X_{k,n}}{X_{k,n} - X_{c,n}} \right) \cdot I_n \tag{29}$$

$$I_{k,n} = \left(\frac{X_{c,n}}{X_{k,n} - X_{c,n}} \right) \cdot I_n \tag{30}$$

For the 5th harmonic the following harmonic currents are produced:

$$X_{k,5} = 5 \cdot 0,01067 = 0,0533$$

$$X_{c,5} = 0,8/5 = 0,16$$

$$I_5 = 165 \text{ A}$$

$$I_{k,5} = \left(\frac{0,16}{0,0533 - 0,16} \right) \cdot 165 \text{ A} = 248 \text{ A}$$

$$I_{c,5} = \left(\frac{0,0533}{0,0533 - 0,16} \right) \cdot 165 \text{ A} = 82 \text{ A}$$

The harmonic voltages across the capacitors bank are

$$U_n = I_{c,n} \cdot X_{c,n} (= I_{k,n} \cdot X_{k,n}) \tag{31}$$

$$\text{For } n = 5: U_5 = 82 \text{ A} \cdot 0,16 \Omega = 13 \text{ V}$$

The total voltage stress is:

$$U = 400 \text{ V} + \sqrt{3} \cdot U_5 + \sqrt{3} \cdot U_7 + \sqrt{3} \cdot U_{11} + \sqrt{3} \cdot U_{13}$$

Excess current caused by harmonics in a capacitor bank is calculated in terms of the effective value of the current:

$$I_c = \sqrt{I_{c1}^2 + \dots + I_{cn}^2} \tag{32}$$

I_c = total current in capacitor bank

I_{c1} = current in capacitor bank at basic frequency (60 Hz)

$$I_{c1} = \frac{Q_c}{\sqrt{3} \cdot U} = \frac{200}{\sqrt{3} \cdot 0,4} \text{ A} = 289 \text{ A}$$

Table 5. Current and voltage values due to the example. The corresponding values are also given for other capacitor ratings.

Cap. kvar	I_{c1} A	I_{c5} A	I_{c7} A	I_{c11} A	I_{c13} A	I_c A
100	144	33	32	137	250	323
200	289	82	124	87	50	340
400	577	330	281	48	36	724
Cap. kvar	I_{k5} A	I_{k7} A	I_{k11} A	I_{k13} A		
100	198	98	171	221		
200	248	190	54	22		
400	495	215	15	8		
Cap. kvar	U_1 V	U_5 V	U_7 V	U_{11} V	U_{13} V	U V
100	400	11	7	20	31	519
200	400	13	14	6	3	462
400	400	26	16	2	1	478

$$I_c = \sqrt{289^2 + 82^2 + 124^2 + 87^2 + 50^2} \text{ A} = 340 \text{ A}$$

Table 5 shows, at all the chosen ratings, that the capacitors will operate at a considerable overvoltage. Note that a 100 kvar bank would be nearly in resonance at the 13th harmonic. The effective value of current in almost 2.5 times the rated value. The capacitors could not withstand this degree of extra stress.

When the rating of capacitors in a system increases in proportion to the load, the danger of resonance is shifted toward the lower frequencies which generally have higher harmonic currents.

It is also noteworthy that the currents flowing into the network are considerably higher compared with those generated by the thyristor drives. However, in practice the above assumption that the impedance would be purely inductive is not valid. At higher frequencies harmonics are damped by the network resistance and resonances are not as likely as in this example.

The problems arising with harmonics are solved by using a harmonic filter as described later in this paper.

The temperature rise of capacitors caused by any increase in losses is not generally a problem with modern low loss metallized-film units. However, capacitors with paper dielectric used to overheat rapidly with excessive harmonics in the network.

3.4.3 Ambient Conditions

Unfavourable conditions will shorten the life of a capacitor and thus incur extra repair and maintenance costs.

The temperature categories according to the new IEC standards for power capacitors cover the temperature range of -50° C to +55° C. For example, the highest permissible mean ambient temperature according to category A is +40° C for a short period but only +30° C for 24 h and +20° C for 1 year. Higher temperatures accelerate ageing of the dielectric, thus shortening the life of the capacitor. Regulators for automatically controlled capacitor banks are usually made for an ambient temperature range of -5° C to +60° C.

In high humidity conditions outdoor type capacitor units should be used since they are suitably protected against corrosion.

4. COMPENSATION EQUIPMENT

4.1 Low Voltage Capacitors

4.1.1 Low Voltage Capacitor Units

A low voltage capacitor unit is built up of several elements connected in parallel. An element consists in principle of two electrodes and dielectric. The elements are made of metallized plastic film and inserted into a plastic cover (Fig. 12).

Unlike capacitors made of aluminium foil or metallized paper, metallized-film capacitors are generally dry without impregnation liquid.

The elements of metallized-film capacitors can be self-heating. After a disruptive discharge, a thin metallized layer will vaporize off from the surface around the breakdown point, and no permanent short-circuit will be left there.

The elements are set into a steel container and the connection cables are connected to the terminals of the capacitor.

Table 6. Capacitor losses for different types of dielectric.

Type of Capacitor	Losses (W/Kvar)		
	Paper	film/paper	All film
LV ≤900V	3	1	0.2...0.5
HV >900V	1.5...2.5	0.5	< 0.2

Most low voltage capacitors are equipped with external discharge resistors so as to decrease the residual voltage of the capacitor from an initial value of ± 2 times the rated voltage U_n to below the level of 50V within 1 minute.

Low voltage capacitors are normally three-phase with three bushing on the cover and star or delta connected internally. Units with three single-phase capacitors in one container can be man-

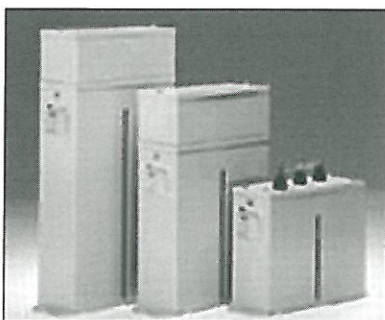

Fig. 12 Low voltage capacitor units

ufactured for special purposes. These have six bushings on the cover and the capacitor may then be connected in star or delta externally.

Among the unit sizes available for the most common voltage range 380...600 V are 2.5, 5, 10, 15, 20, 25, 30, 40, 50, 60, 75, 90 and 100 Kvar, and the capacitance tolerance is $-5...+10\%$.

4.1.2 Fixed Low Voltage Capacitor Banks

Fixed capacitor banks consist of parallel connected units installed in a rack. The capacitance tolerance of a bank is $-0...+10\%$.

Due to the large inrush current of a fixed bank, slow acting fuses dimensioned of 1.65 times the rated current must be used. According to general standards, the connection cable must be able to carry a continuous load of 1.35 times rated current.

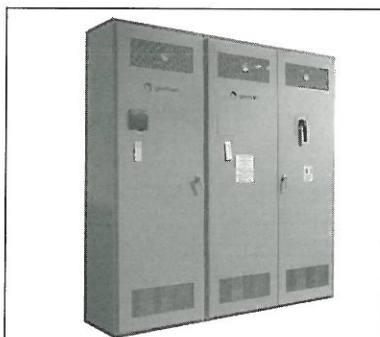

Fig. 13 Cubicle type automatic capacitor bank

4.1.3 Automatically Controlled Low Voltage Capacitor Banks

Automatically controlled capacitor banks are equipped with fuses and contactors controlled by a reactive power regulator, on which a desired target value of power factor (cos ϕ) and inductive and capacitive operating limits can be set.

The level of reactive power is monitored by means of current transformers and the regulator switches capacitors on and off according to demand.

A single step may compromise either one or several capacitor units; in the latter case the second unit is controlled via an auxiliary contact on the contactor of the first unit on so on. In this way a time

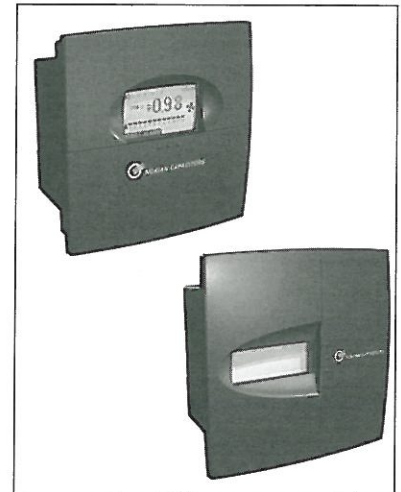

Fig. 14 Power factor controllers.

lag equal to the operating time of the contractor is introduced and the overall inrush current is thus reduced.

Steps can be equal or different sizes, but if they are unequal the first (i.e. the smallest) determines the increment. The ratio of steps with respect to the first can be any of the following:

1:1:1:1:..., 1:2:2:2:..., 1:2:3:3:..., 1:2:3:4:... or 1:2:4:4:...

It is generally advisable to use standard banks with steps of, say, 50Kvar. With smaller banks, units of 25..30 Kvar may be used for the first steps and with the smallest, units of even smaller power rating. Such arrangements are obviously more expensive per Kvar than those comprising larger units.

Very large banks are usually divided into smaller subgroups, each with an individual connection cable and main fuses but with a common reactive power regulator.

The main fuses should be slow acting and dimensioned for 1.65 times rated

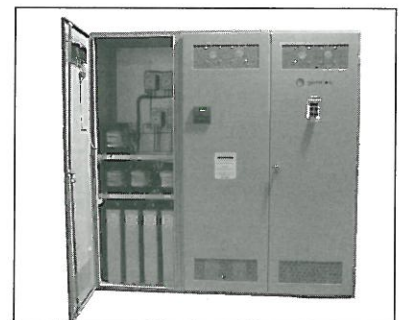

Fig. 15 Automatic capacitor bank with blocking reactors

current.

4.2 High Voltage Capacitors

4.2.1. High Voltage Capacitor Units

One-phase high voltage capacitor units are equipped with two bushings or one bushings with live case. Three-phase units are internally either delta or star connected.

A capacitor unit consist of parallel and series connected elements. Series coupling is needed to keep the element voltage at a suitable level (about 2000 V).

The elements of modern HV capacitors are made of aluminium foil, separated by two or more layers of polypropylene film dielectric. Units with paper or mixed dielectric, commonly used before, have higher losses (see table 2).

The capacitor elements are inserted into a steel container. The units is then filled with a suitable, environmentally safe impregnation oil, and the containers are hermetically closed.

HV units equipped with internal element fuses are manufactured up to 14000V of rated voltage. Internal discharge resistors decrease the residual voltage from $\pm 2 \times$ rated value to below 75 V within 10 minutes, according to IEC standards.

The most common unit sizes are 50,100,167,200,250,300 up to 1000 Kvar and the capacitance tolerance is $-5... +10\%$. The units are manufactured for the voltage range 1...22 kV, and the most common unit voltages are 3300, 4000, 4500, 6350, 6600, 7600 and 8000 V.

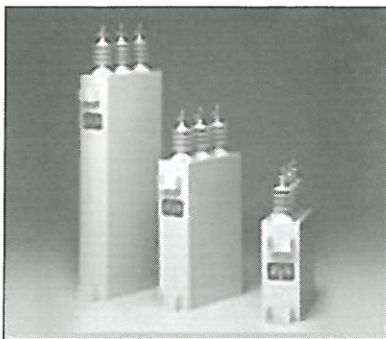

Fig. 17 One-phase high voltage capacitor units

4.2.2 High Voltage Capacitor Banks

High voltage capacitor banks are used at substations and in industry, on long transmission lines, and at points in HV networks suitable for maintaining reactive power balance.

High voltage capacitor banks are usually built up for single-phase HV units, the required number in series depending in the voltage and the number in parallel on the voltage and the number in parallel, on the power.

In order to divide the voltage evenly, an equal number of units are connected in parallel in each series group. Series groups are separated from each other by support insulators mounted between the racks. Capacitor banks attached to a busbar are equipped with a beaker. If necessary, current limiting reactors can be supplied to reduce the inrush current to a value suitable for the breaker.

The main purpose of shunt capacitor banks is to produce restive power near enough to point of consumption in order to reduce losses, cut the price of reactive power, increase the voltage, and improve the power transmission capacity of the line section.

4.3 Protection of Capacitor Banks

In electricity networks the purpose of all protection is to protect against overcurrents and overvoltages and to minimize the effect of these, considering the eco-

nomical and technical restrictions and safety regulations.

Internal protection of a bank comprises either internal or external fuses and unbalance protection, whereas externally the bank is protected against overload, overvoltage and short-circuit.

4.3.1. Internal and External Fuses

There are two types of fuses used for capacitors, internal or external. When the reactive power of a capacitor unit was only a few Kvar, the most natural method to protect the capacitor was with an external fuse, since in the case of a breakdown the lost reactive power was small. However, now that one capacitor element has a capacity of about the same value as a unit had previously it is reasonable to protect each separate element with an internal fuse.

If the capacitor unit is protected with

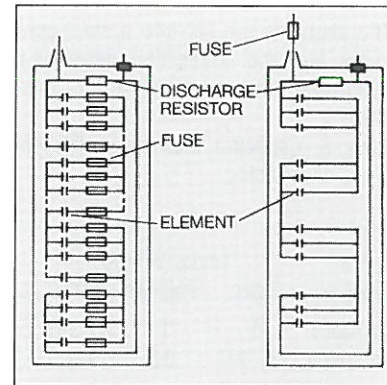

Fig. 18 Internally fused unit Externally fused unit

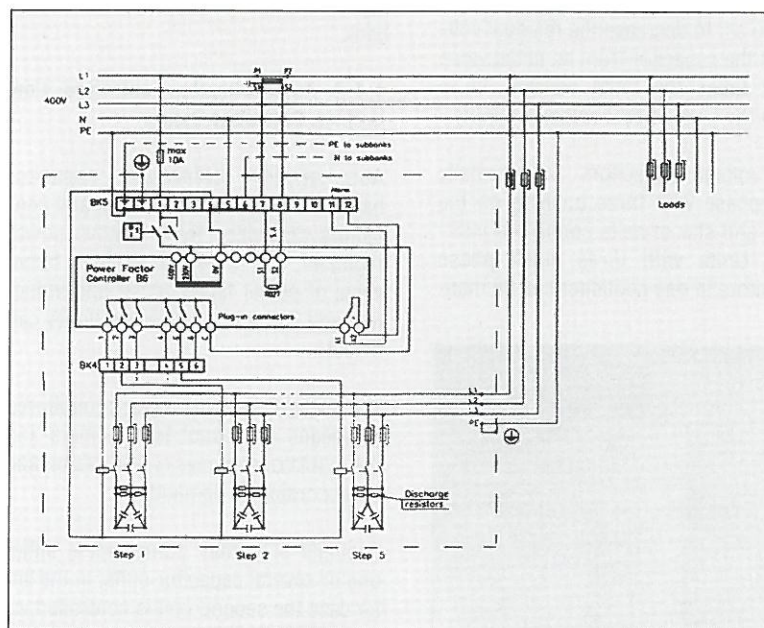

Fig. 16 Schematic diagram of an automatically controlled capacitor bank with power factor controller.

internal fuses the lost reactive power in the case of a blown fuse is very low (approximately 2% of a unit). Because of the low percentage power loss there is no need to replace the entire capacitor unit, hence preserving continuity of operation and saving replacement costs.

If the unit is protected with an external fuse the whole unit is lost and nearly always necessary to replace the faulty unit immediately. It is, therefore, obvious that by using internally fused units the need for spare units is much lower than by using external fuses.

4.3.2 Unbalance Protection

HV banks are usually wired in either single or double star. If the impedance of one phase changes with respect to the other two phases, the star point of the bank shifts. This occurs when element fuses in a capacitor are blown as a result of a disruptive discharge.

At the same time the voltage division within the bank is also changed. Hence, the bank must be switched off before the operation of the fuses would cause a voltage rise considerably above the permitted 10% overvoltage.

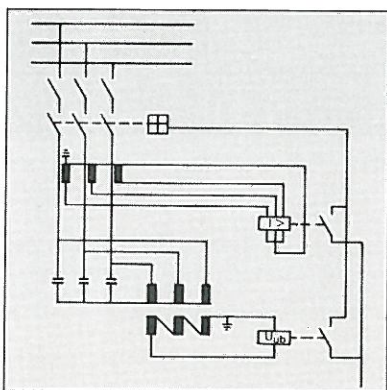

Fig. 19 Schematic diagram of an HV capacitor bank connected in star with unbalance protection.

Double pole insulated voltage transformers are used for unbalance protection of single star connected banks. The transformer primaries are connected in parallel with the phase banks and the secondaries form an open delta. The unbalance voltage generated in the open delta operates the breaker through a voltage relay.

Where there is a sufficient number of parallel connected units, it is advisable to connect the bank in double star. Unbalance protection is then carried out by a current transformer connected between the two star points, and an overcurrent relay (Fig.20). The time settings are 5 s for alarm and 0.1 s for tripping.

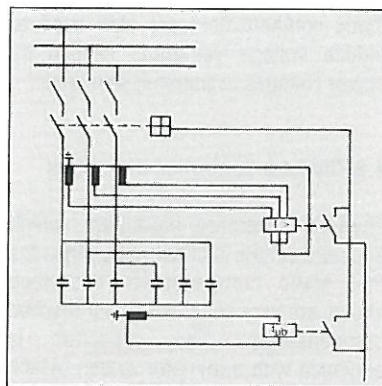

Fig. 20 Schematic diagram of an HV capacitor bank connected in double star with overload, short-circuit and unbalance protection

By using internal fuses, a reliable unbalance protection can be performed, protecting the banks against any major damages during a fault operation of the network or the banks.

4.3.3 Overcurrent and overvoltage protection.

Overload and short-circuit protection of an HV bank is normally carried out by means of current transformers and a two-step overcurrent relay.

The capacitor bank is characteristically self-protective against switching and lightning overvoltages because of its low impedance at high frequencies.

Overvoltage protection is therefore usually included in the protection of other equipment. If separate overvoltage protection is required, the discharge capacity of the protective device is of great significance. Sometimes a tripping overvoltage protection is needed at power frequency during low-load periods.

4.4 Harmonic Filters

Harmonic filters provide another source of compensation. In a filter, a reactor is connected in series with a capacitor bank. With a suitable reactor inductance, the series circuit of capacitor and reactor forms a low impedance at a desired harmonic frequency. Thus, the major part of the harmonic current flows into the filter and not into the network.

At the same time the filter provides capacitive reactive power at the base frequency.

Among the problems caused by harmonics are interference to telecommunications, disturbances to the control

and protection system of the network, malfunctioning of relays and dangerous overvoltage due to resonance. The extra losses that occur in cables also of significance: they cause loss of energy and excess temperature rise in the equipment. The most frequently encountered and potentially harmful harmonics are the 5th and 7th, which are generated by 6-pulse rectifiers.

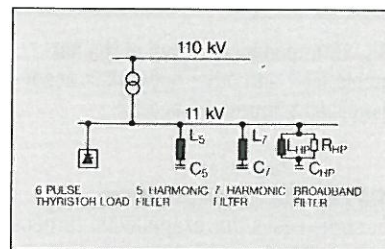

Fig. 21 Typical filter construction.

Harmonic filters can be connected to either LV or HV circuits. Where there are several harmonic generating loads, each fed by a distribution transformer, it is often more economical to eliminate the harmonics by installing filters centrally at the HV busbar, rather than to have separate filters on the LV side of each transformer.

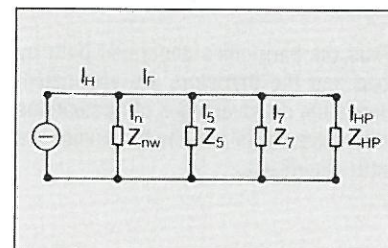

Fig. 22 Equivalent circuit of the harmonic filter and the network in accordance with Fig. 21.

A typical filter construction is shown in fig.21. The lower harmonics (5th and 7th) have individual circuits and the higher harmonics (11th, 13th) a common high-pass filter.

The circuit in Fig.22 can be simplified furthermore, consisting of parallel coupled network impedance Z_{nw} and filter impedance Z_f . The impedance vary according to frequency as shown in Fig.23 (absolute values). The currents drawn consequently depend on them, and can be expressed as follows:

$$I_n = \frac{Z_f}{Z_{nw} + Z_f} \cdot I_h \quad (33 a)$$

$$I_f = \frac{Z_{nw}}{Z_{nw} + Z_f} \cdot I_h \quad (33 b)$$

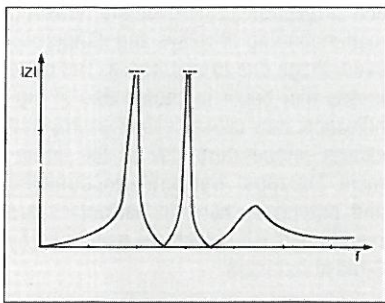

Fig. 23 Impedance curves of the harmonic filter and other network in accordance with figures 21 and 22.

$$Z_{nw} + Z_f$$

4.5 Fast Static Compensators

In some cases, for example arc furnace and welding machines, there are very rapid fluctuations in reactive power within a short period – i.e. a few cycles. Traditional methods of reactive power control are not suitable since they are too slow for such variations.

The fast static compensator consists of a fixed shunt capacitor bank, normally tuned as a filter, and a thyristor-controlled shunt reactor. By controlling the reactor current, the total reactive power supplied by the f.s.c. into the network is correspondingly adjusted.

Thus the harmonics generated both by load and the thyristors are eliminated. Hence the disadvantages of fluctuations in reactive power and the harmonics are both minimized.

Static compensators are also used to reduce voltage variations caused by power changes in transmission lines.

equipment can rapidly compensate for fast reactive power fluctuations in welding machines and the consequent voltage variations.

4.6 Thyristor Controlled capacitors

Thyristor controlled capacitors, which are more simple in construction than the fast static compensators described above, are very suitable for fast reactive compensation. The capacitor is equipped with a thyristor switch, which replaces the traditional contactor. Regulator operations are combined with the automatic thyristor controls. This

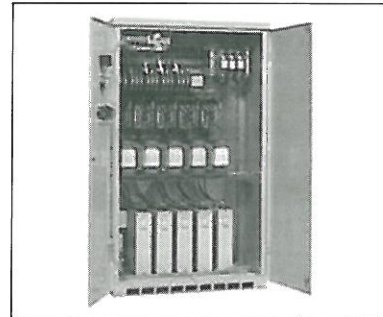

Fig. 25 Thyristor Controlled capacitors bank.

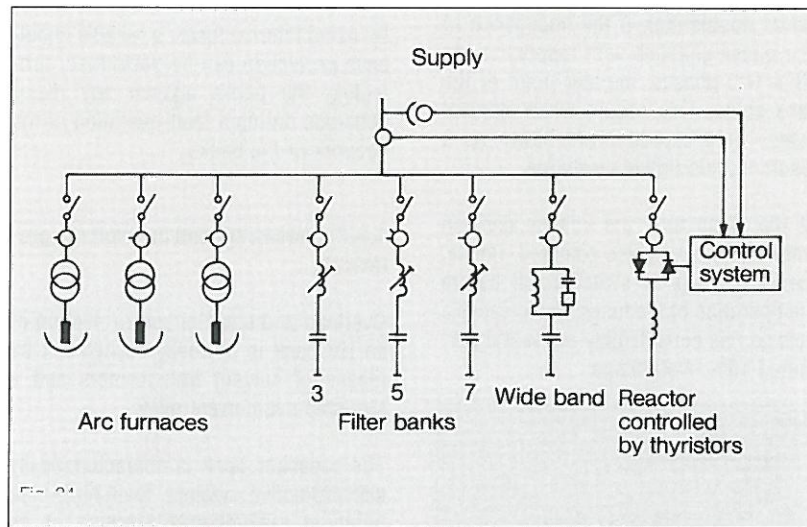

Fig. 24 Fast static compensator for arc furnaces.

5. SUMMARY

The most economical way of producing reactive power required by most electrical devices is by the use of capacitors.

Capacitors reduce network losses and voltage drop, and the transmission of reactive power is avoided. This means considerable annual savings.

By series capacitor bank, voltage may be raised to a desired level. Parallel capacitor banks can be used for individual, group or central compensation.

The influence of possible harmonic components must be taken into account when designing the system.

This guide for power factor correction with capacitors is published by NOKIAN capacitors, a member of NOKIAN Corporation, Finland. NOKIAN has over 40 years' experience in reactive power compensation, providing a wide range of products which combine high quality and reasonable price. NOKIAN is today one of the leading manufacturers of capacitor in the world.

For more detailed information, don't hesitate to contact us or our local representative.

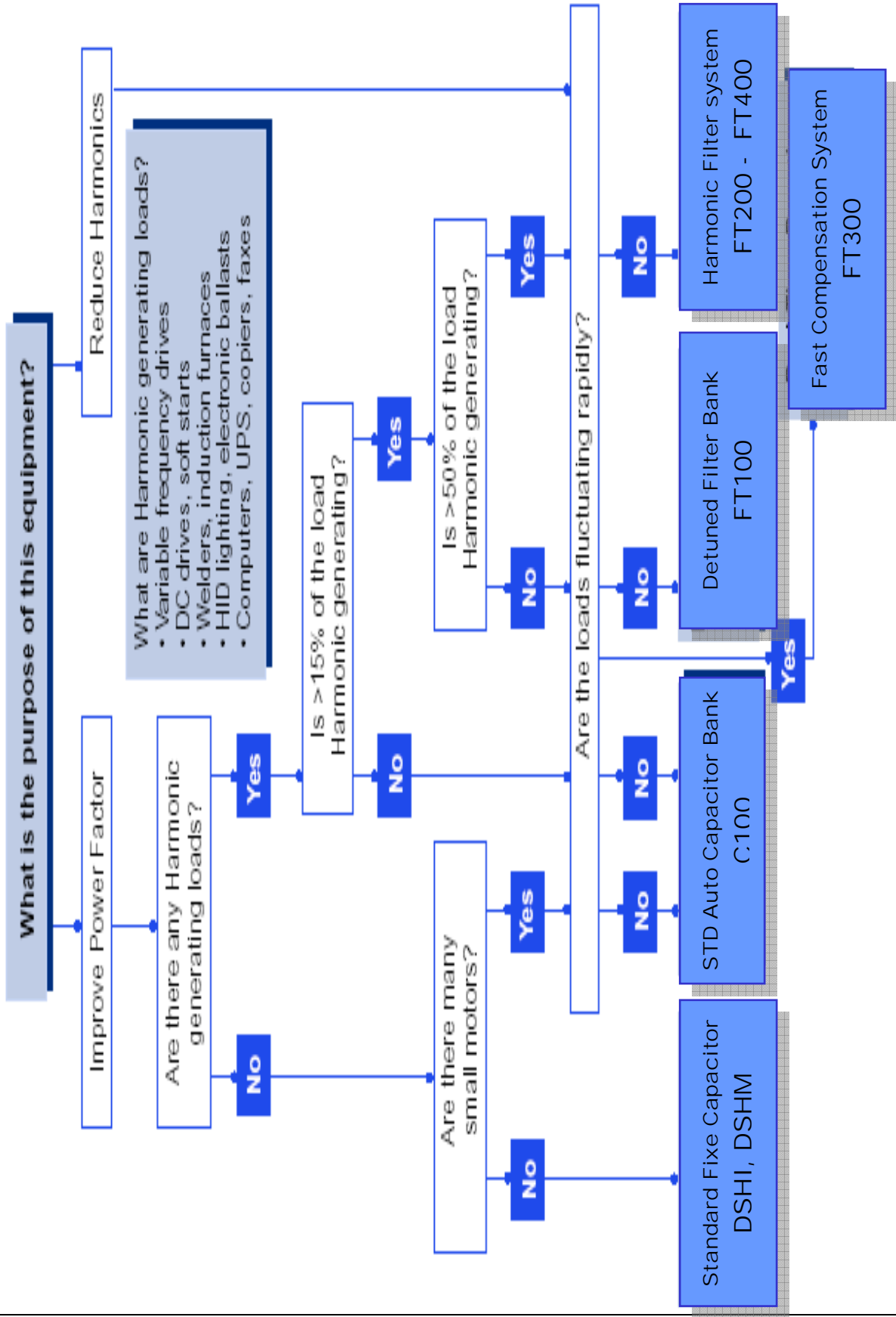

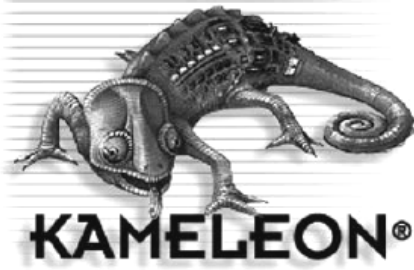

KAMELEON®



With its Kameleon line, Gentec provides a solution for all your lighting control needs. Whether it is with the K4 series for small to medium-sized facilities, or with the K8 series with the Echelon^{MD} technology for larger installations, our Kameleon line adapts to your specific needs.



Whether you manage a hotel, a nursing home, a shopping centre or any other commercial building, you are committed to both your client's comfort and your facility's profitability.

Gentec's Ambiance system was developed in order to help you achieve these two goals. This integrated power management system enables you to control power consumption while preserving comfort for your tenants

COMPLETE SOLUTION IN POWER QUALITY CORRECTION



Power Quality
Manager



C100
Auto Bank



FT100, FT200
Passive Filter



DS100, DS200
DriveSaver



FT400
Active Filter



HVCE 3 Ph. Cap
(2400@6900 V)



C1000 & FT1000
HV Metal Enclosed
5,15,25 kV