

Redundant Battery Charger, Master-Slave, MA Series

The redundant systems, MA Series, comprise two (2) battery chargers. Normally, the master charger powers the load. If the master charger fails, then the load is automatically transferred to the backup (slave) charger.

The MA Series battery chargers have been designed to provide a most reliable power source for battery and connected loads. The technology uses thyristors with conduction angle control.

Typical clientele are the heavy industry and electricity service companies.

A microprocessor display module provides the measurement (voltmeters, ammeters), the monitoring (comprehensive alarm system), and battery optimal charge. The battery charger accepts all industrial battery types.

- ✓ Optimal battery recharge
- ✓ Master-slave redundancy
- ✓ Ultra heavy duty
- ✓ Life expectancy of more than 25 years
- ✓ Support by a large team of engineers and technicians



*Redundant Battery Charger
125 VDC, 150 A*

MAIN FEATURES

- Output voltage 125 VDC (other output voltages available as options);
- Thyristor rectifiers;
- Master-slave redundant chargers;
- Can be used with any type of industrial battery;
- Cabinet includes the chargers and the battery can also be shipped inside a single cabinet;
- User-friendly person-machine interface (PMI) ("Parameter mode" in the display module to configure alarms and functions, and also to gain access to numerous additional information)

MASTER-SLAVE REDUNDANCY, MAIN FEATURES

The redundant systems, MA Series, comprise two (2) battery chargers. Normally, the master charger powers the load. If the master charger fails, then the load is automatically transferred to the backup (slave) charger.

In order to prevent premature wear of one of the two (2) chargers, any charger may be manually selected as master (or automatically every 34 days). Thus, both chargers should show even wear after many years of use. Also, this ensures that both chargers remain in good operational state. Note that one parameter available on the display module shows the number of months each charger has powered the load.

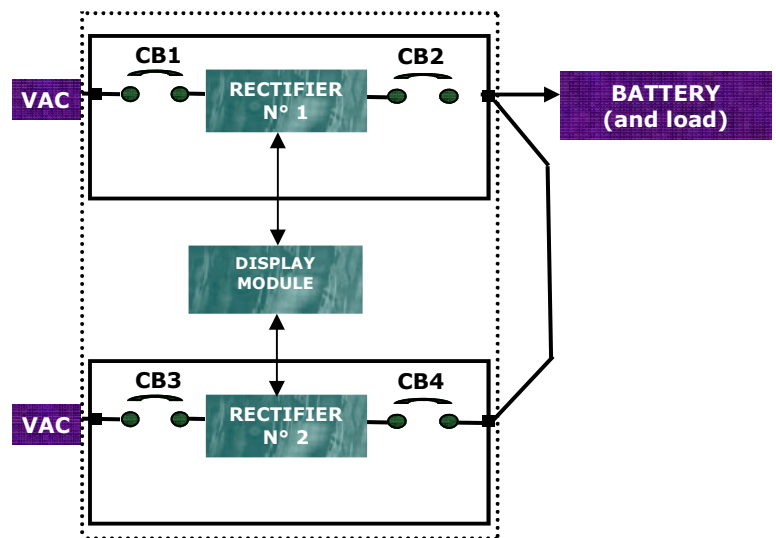

ALARMS

The battery charger is equipped with a very efficient alarm system. The alarms and indications appear as lights on the display module. Also, they are connected to normally open alarm contacts (N.O., 125 VDC, 0.5 A). The display module "Parameter" mode allows for alarm configuration.

INDICATING LIGHTS

The display module lights show the charger operational status:

- Master charger (n°1 or n°2)
- Operating charger (n°1 or n°2)
- Load on master/Load on slave
- Manual equalize/Automatic equalize
- Float voltage/equalize voltage
- Current limit (n°1 or n°2)

ALARMS	
(s=standard, o=option, na=not available)	
Master charger off limit (master rectifier slightly out of adjustment)	S
Slave charger off limit (backup rectifier slightly out of adjustment)	S
Master charger failure (master rectifier failure)	S
Slave charger failure (slave rectifier failure)	S
AC failure	S
Microprocessor failure (display module and alarm system failure)	S
Load on slave charger	S
Equalize voltage	S
Excessive battery recharging (defective battery)	S
Ground fault (\pm)	S
Low battery voltage	O

Automatic equalize cycle

To prevent the battery from premature aging, the equalization cycles shall take place only when they are really necessary. The charger offers great flexibility with regard to conditions that may result in the automatic equalize cycle:

- The charger operates at rectifier current limit for more than 36, 60 or 72 seconds;
- The battery has remained at minimum voltage threshold for more than 60 seconds;
- A periodic equalization is required every 30 days.



Display Module and Control Cards

Any of these conditions may easily be set to "ON" or "OFF", or configured on-site with the "Parameter" mode available on the display module.

CHARACTERISTICS

Input voltage:	120, 208, 220, 240, 277, 480, or 600 VAC, one or three phases, 60 Hz $\pm 6\%$ (50 Hz optional);
Output voltage:	24, 48, 110, 125, 220, or 250 VDC, other output voltages available upon request
Output current:	10, 20, 30, 40, 50, 60, 80, 100, ... , 600 A (setting range 50 to 100%);
Voltage regulation:	$\pm 0.25\%$ for a load variation of 0 to 100% of the nominal output current, combined with a $\pm 10\%$ variation of input voltage, combined with a $\pm 5\%$ frequency variation. No battery is connected to the system during these measurements.
Ripple:	2% RMS of the output voltage for the same conditions specified in "Voltage regulation".
Efficiency:	90%, at full load
Protection:	Input: thermal magnetic circuit breaker / output: thermal magnetic circuit breaker (2 poles)
Ventilation:	natural convection except for the battery section that may be provided with a fan (system with vented battery in the same cabinet as the battery charger).
Acoustical noise:	less than 65 dbA at one meter, at nominal power
Environmental conditions:	operating temperature: -10°C to 50°C / storing temperature: -20°C to 70°C relative humidity: 0 to 95% at 25°C

Quality assurance program: ISO9001:2008

TESTS

Electric strength test: IEC 60255:5

Surge withstand capability test (SWC): satisfies ANSI/IEEE C37.90.1/ IEC 60255-22-1/-4

Dry-heat test: satisfies IEC 68-2-2 /

Damp-heat test: satisfies IEC 68-2-3 /

Cold test: satisfies IEC 68-2-1 /

Radiated electromagnetic field requirements immunity test : satisfies IEC 801-3

Electrostatic discharge (ESD): satisfies IEC 61000-4-2

Fire resistance: satisfies UL94V0

Vibration test: satisfies IEC 255-21-1

DISPLAY MODULE

- Instrumentation (digital):
 - Battery charger: DC voltmeter, range: 0-120%, accuracy: 0.1%
 - Battery charger: DC ammeter, range: 0-120%, accuracy: 1.0%
 - Battery: DC voltmeter, range: 0-120%, accuracy: 0.1%
- Other feature: The "Parameter" mode provides for alarm and function configuration, and for access to numerous additional information: number of months each charger has powered the load; in equalization, remaining time before the float voltage returns; remaining time before the automatic selection of a new master charger; ground leakage value, positive or negative current (mA).

