



Inverters

Gentec inverters, *OND3CS Series*, compatible with 19" relay racks, are recognized for their high reliability and flexibility



OND3CS Series

The **Gentec** inverters, *OND3 Series*, were designed to provide a high level of reliability and flexibility.

The sub-series *OND3CS* combines inverter modules with a static switch module that operate as a true on-line inverter. In the unlikely event of inverter modules failure, the power from the emergency AC line brought in automatically and without interruption, keep supplying the AC load. The system is completed with an external “make before break” maintenance bypass switch to isolate the system with no power interruption.

The static switch module integrates an HMI interface (Human Machine Interface) that includes an LCD display's control panel that allows to configure easily the different parameters in the field and to visualize the complete operation of the system. Alarm monitoring and issuing are also offered via the LCD display's control panel, LED indicators, and extended through form-C contacts.

Single Line Diagram, *OND3CS Series*

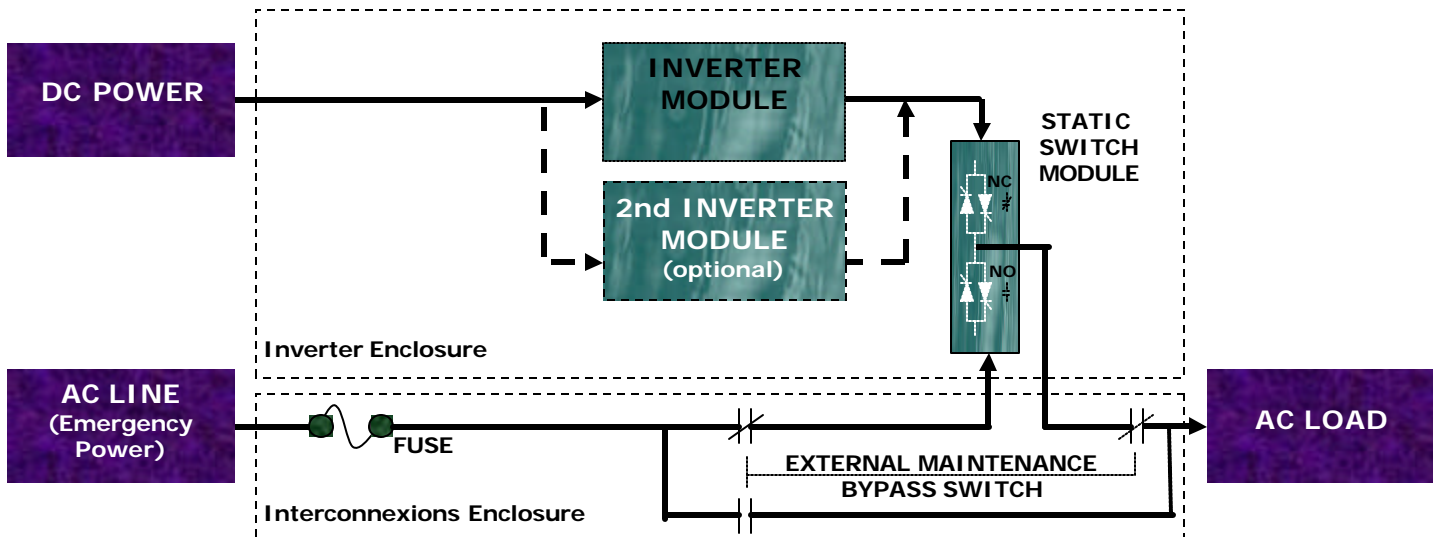

Configurations, *OND3CS Series*

In the *OND3CS Series*, the inverter modules are offered in a regular or parallel configuration:

Regular inverters:

In this configuration, a single inverter module supplies the load.

Parallel inverters, power capacity:

In this configuration, inverter modules operate in parallel to increase the output power. They share the load equally.

Parallel inverters, N+1 redundant inverters:

In this configuration, inverter modules operate in parallel. They share the load equally. If one fails, the other inverter modules supply the load.

Other configurations:

OND3CS Series is the *OND3* sub-series that offers the most features. The *OND3 Series* offers other configurations. For example, it is possible to use inverter modules as stand alone inverters that include a relay to transfer the load, in case of inverter failure, to the AC line (or to an other inverter module). **Consult factory for custom assemblies based on the end-user application.**

Inverter Module Technology

The Gentec inverter modules provide safe, pure sine wave, reliable power to critical loads. These true on-line inverters incorporate pulse width modulation (PWM) control combined with high frequency IGBT transistors.

A microcontroller controls the PWM waveform, the synchronization with the AC line and the steady-state voltage regulation even when the inverter supplies non-linear loads.

BENEFITS

- » Well suited for use in utility substations, heavy industries and telecom sites
- » Custom built products available
- » Mature and proven technology
- » Easy to maintain
- » Life expectancy over 20 years

SYSTEM FEATURES

- » 1000W/1000VA inverter module
- » Short-circuit current: 250% for 35 sec. to eliminate short-circuits
- » Compatible with nonlinear loads
- » Parallel for power capacity or redundancy
- » Pure sine wave output
- » Input/Output isolation
- » 2ms static switch

Dimensions

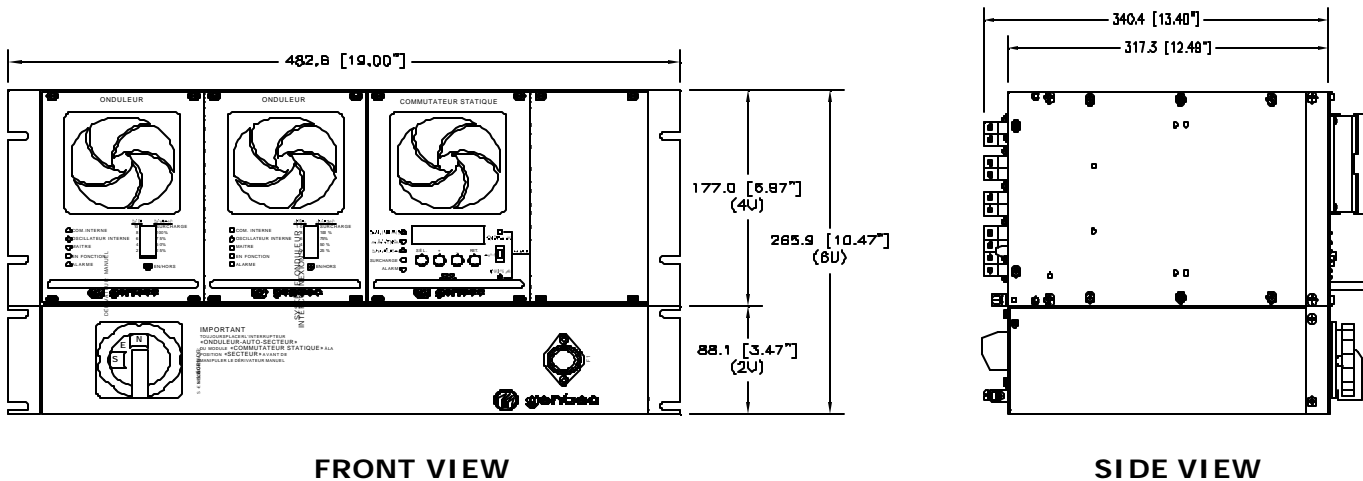

Model Number

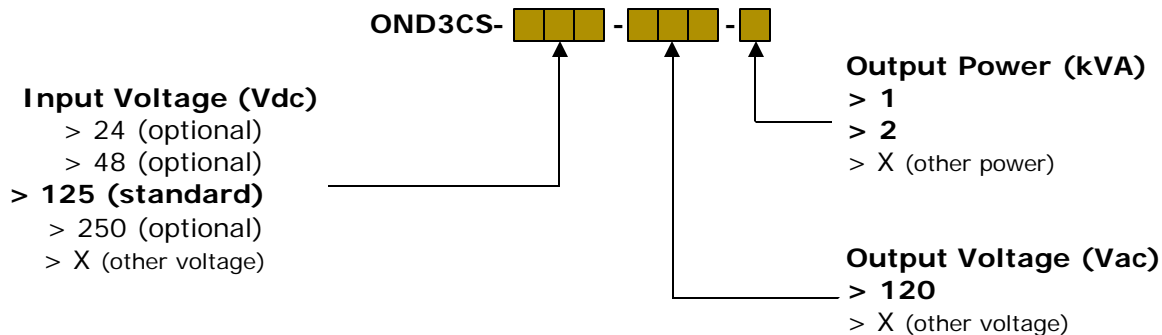

Electrical Specifications	
DC INPUT	
Input Voltage	125Vdc (optional: 24, 48 or 250Vdc, consult factory)
Voltage Range	100Vdc – 142Vdc
AC OUTPUT	
Output Voltage	120Vac, 60hz, single phase (isolated from the DC input)
Output Power (PF=0.7 to 1.0)	1kVA (1kW) / inverter module
Frequency	60Hz (optional 50Hz, consult factory)
Voltage Regulation	Static: $\pm 1.0\%$ for 0% - 100% load variation Dynamic: $+4\%/-8\%$ for 50% load variation
Frequency Regulation	$\pm 0.15\%$ (in free-running mode)
Crest Factor	>2.5
Overload	125% for 10 min. / 150% for 10 sec./ short-circuits current: 250% for 35 sec. (to eliminate short-circuits, consult factory)
Power Factor	1.0 to 0.7 lagging
Efficiency (Full load)	82% (at rated power)
Harmonic Distortion (THD)	3.0% max.
Measuring Apparatus	AC ammeter (bar graph)
STATIC SWITCH	
Transfer Time	2.0ms (inverter output is synchronized on the emergency AC line)
Maintenance Bypass Switch	Included (standard feature)
Measuring Apparatus (accessible through the LCD display's panel)	DC voltmeter, DC ammeter, AC voltmeter, AC ammeter, and frequency meter accuracy of 1.0% (excepted frequency meter: 0.2%)
ALARMS	
Alarm Monitoring	High/Low Vdc, High/Low Vac, Vac Failure, High Temperature, Fan Failure, Overload, Load on AC line, AC Line Failure, Synchro. Failure, etc. LED, alarm codes on LCD display's panel, dry contacts form "C", RS485 serial port (optional, consult factory)
Environmental Specifications	
Temperature	
Operating Temperature	0 °C—55 °C (32°F—131°F), derating of -2%/ °C over 40 °C
Storage Temperature	-20 °C—70 °C (-4°F—158°F)
Relative Humidity	0—95% non-condensing
Cooling	Forced (temperature controlled variable speed fans)
Audible Noise	55dBA max. @ 1m (3ft), at rated power
Altitude Derating	0% @ 0 - 1000m (3300ft)
Test Specifications	
Fire Resistance Testing	UL 94V0
Shock, Vibration, Bump, Seismic Testing	IEC 60255-21-1
Surge Withstand Capability (SWC) Testing	IEC 60255-22-1 /-4
Dielectric Strength Testing	IEC 60255-5
Impulse Voltage Testing	IEC 60255-5
ESD Testing	IEC 61000-4-2
EMC Radiated / Conducted Testing	IEC 61000-4-3 /-6/-11, IEC CISPR 22
Dry / Damp Heat Testing	IEC 68-2-2 / IEC 68-2-3
Quality Assurance Program	ISO 9001 (2000)
Mechanical Specifications	
Installation	19" or 23" rack mounted
Dimensions (HxLxD)	
Inverter enclosure	177.0 (4U) x 482.6 x 340.4 mm (7.0 (4U) x 19.0 x 13.4 in.)
Interconnexions enclosure	88.1 (2U) x 482.6 x 340.4 mm (3.5 (2U) x 19.0 x 13.4 in.)
Material	Aluminum
Color & Finish	Beige, alodine 1500 clear (other colors and finishes on demand)